

astrapac
HEAT SEALING MACHINERY

ONYX PRO

OVERHEAD ADVANCED IMPULSE SEALER



**A SEMI AUTOMATIC MODEL WITH
PRECISE PARAMETER CONTROL FOR
REPEATABLE RESULTS.**

**INCORPORATES THE FACILITY TO SET
AN ACCURATE SEALING TEMPERATURE**

ONYX PRO MODEL OF HEAVY DUTY OVERHEAD HEAT SEALER

A high specification air operated impulse sealing machine with precise parameter control. Significant for critical applications, where repeatable high-quality seals are paramount set within strict limits.

The machine features a highly developed processor module that exercises absolute control over the sealing process. A precise sealing temperature is able to be set, alongside accurate heating and dwell time, imposing total control of the seal cycle. As part of its function, the controller continually monitors and governs the temperature of the heating element, without the use of a thermal sensor. Throughout the duration of the sealing cycle, it precisely measures the elements resistance electronically, adjusting the power into the sealing jaws, maintaining the pre-set temperature.



ONYX PRO model is suitable for the sealing of a wide range of plastic based films, including single web materials e.g. polythene's, polypropylenes, co-extruded, to laminated plastic and coated foils and papers. This machine incorporates many of the features of our conventional ONYX IP65 model. These includes, both sealing jaws being heated for delivering a greater power capacity, pneumatic operation, providing the benefits of a positive action, for both the opening and the closing of the sealing jaws (no spring return), plus imposing a high pressure on the area of seal. A key attribute, is being able to set a lower sealing temp for a longer heating time period, allowing greater penetration of gusseted or thicker films or to combat mild product contamination.

Other features of this innovative controller include, the facility to set a minimum temperature at which the jaws open, rather than a set cooling time (as the application dictates). This helps negate any underlying residual heat build up in the jaws, a commonplace problem with repeated operation, (guaranteeing the seal has welded perfectly). Built in alarms prevent the sealers operation, should there be a deviation from the pre-set parameters. An error code will display the nature of the fault.

Other notable features include, an extended life of the sealing jaw consumables (tapes and heating elements etc). With a controlled sealing temperature, the components of the sealing jaw are not subject to excessive heating, resulting in burn out, etc, a common frustration with standard impulse sealers. This also in turn has a direct effect on reducing maintenance requirements.

The ONYX Pro is produced in three sizes and manufactured in 304 stainless steel, built to an industrial specification with an IP65 ingress classification, qualifying this model for use in relatively harsh environments. A robust trolley base section incorporated braked wheels for manoeuvrability of the sealer, jacking studs are provided to disable the wheels and set a fixed position as required. To cater for a variety of bag sizes / volumes etc, the machines working height can be altered. A manual rise and fall mechanism on the vertical column, adjusts the working height within a range (See table over).

To provide greater flexibility, a height adjustable **Bag Support / Platform** (suitable for bags up to 25Kg) is available as an optional extra. This allows the bag standing height to also be manually raised, to enable the working height to be set at a comfortable level for the operative, it also provides a secondary height adjustment, relevant for smaller pack sizes.

Operation of the machine is simple, sealing is initiated via the use of a IP67 rated low voltage electric foot switch (or push button option available). The jaws open automatically once the seal cycle is complete.

Two safety circuits are integral to the machine, firstly a separate low pressure air system closes the sealing jaws, this minimises any risk or accidental injury to an operative. Only when fully closed, will heat and high pressure air circuit engage to produce a strong and durable seal.

A secondary electrical protection circuit (auto abort), returns the sealing jaws to the open position. If a programmed closing time is exceeded, even if the footswitch remains activated, It is assumed that an object being packed or operatives fingers may be unintentionally between the sealing jaws.

OPTIONS

Stainless steel bag support platform (to suit up to 25 Kg.)
Height adjustable. (As shown on front image).

Push button cycle start instead of footswitch

Self levelling feet (see image across), instead of braked wheels.

A range of gravity roller tracks (to suit application)
(see image across).

Motorised belt conveyor with stop/start operation via a foot switch.
assists the operative in presenting a regular supply of heavy bags to the sealer.



TYPICAL GRAVITY ROLLER CONVEYOR OPTION
ALSO SHOWN SELF LEVELING FEET OPTION

TECHNICAL SPECIFICATION

| MODEL ONYX PRO | 700 | 900 | 1100 |
|-----------------------------------------|-----------------------------------------|--------|---------|
| Seal length mm | 700 mm | 900 mm | 1100 mm |
| Seal width mm | 6 mm | | |
| Sealable thickness 2 x 250mu | 2 x 250mu (2 x 1000G) | | |
| Sealing Temperature Range | Processor controlled, Ambient to 300° C | | |
| Heating Time | 0-2.5 secs | | |
| Cooling / Dwell Time | 0-99 seconds | | |
| Width of base frame (B) | 77 cms | | |
| Depth of base frame (C) | 90 cms | | |
| Seal height from floor Max-Min cms | 120-102 cm | | |
| Available head room above the seal line | 90 mm | | |
| Jaw opening | 40 mm | | |
| Sealing jaw actuation | Pneumatic | | |
| Power Supply | 230v AC 50Hz (115 volt optional) | | |
| Power VA (watts) | 1800 | | |
| Dwell time | 0-9.99 seconds | | |
| Air pressure | Max 5bar (80psi) | | |
| Air consumption | 0.23dm³/sec (0.5cfm) | | |
| Std machine finish | 2B brush finish | | |
| Machine Weight Kg | 62 | 68 | 80 |

DIMS FOR SEALER

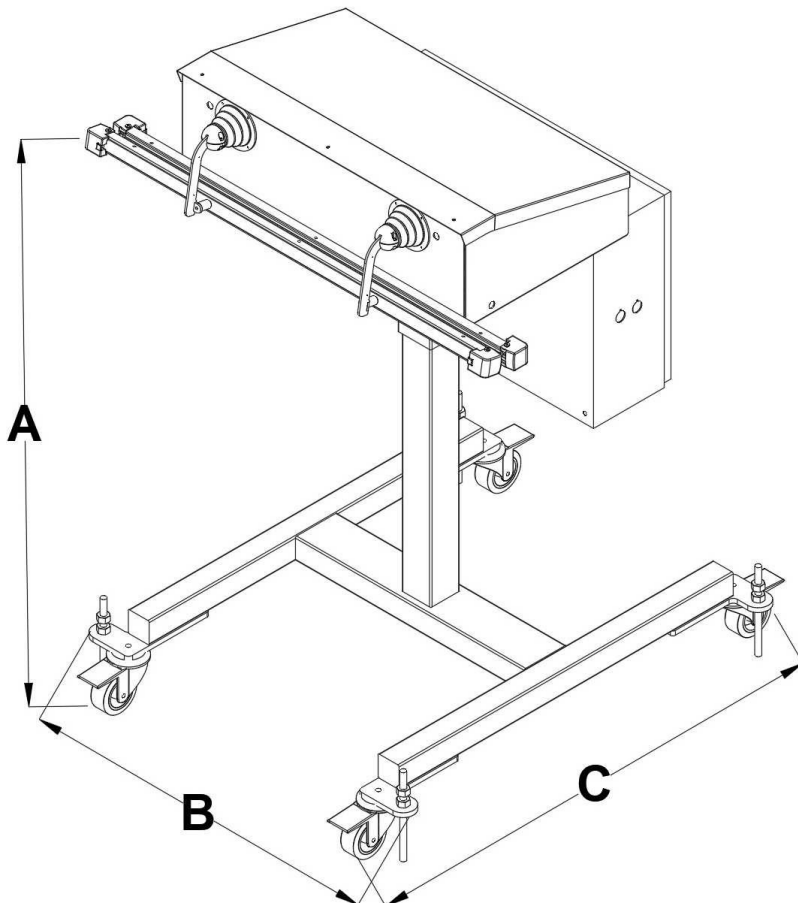

PRODUCT SUPPORT TRAY OPTION

